



**OUTDOOR**  
ESSENTIALS®

# HOMESTEAD 2X8 CEDAR ELEVATED GARDEN PLANTER – ASSEMBLY INSTRUCTIONS

ACTUAL SIZE: 90-1/4 in. L x 25-1/4 in. W x 32-3/4 in. H

## Parts List

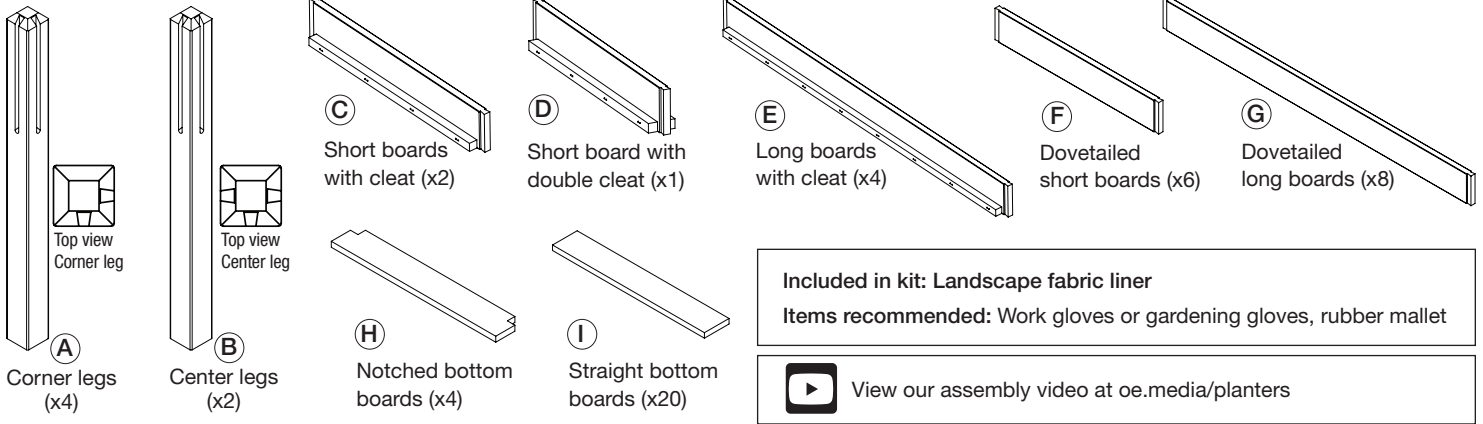

## Assembly – Step 1 Slide boards with cleats into the legs in the order shown.

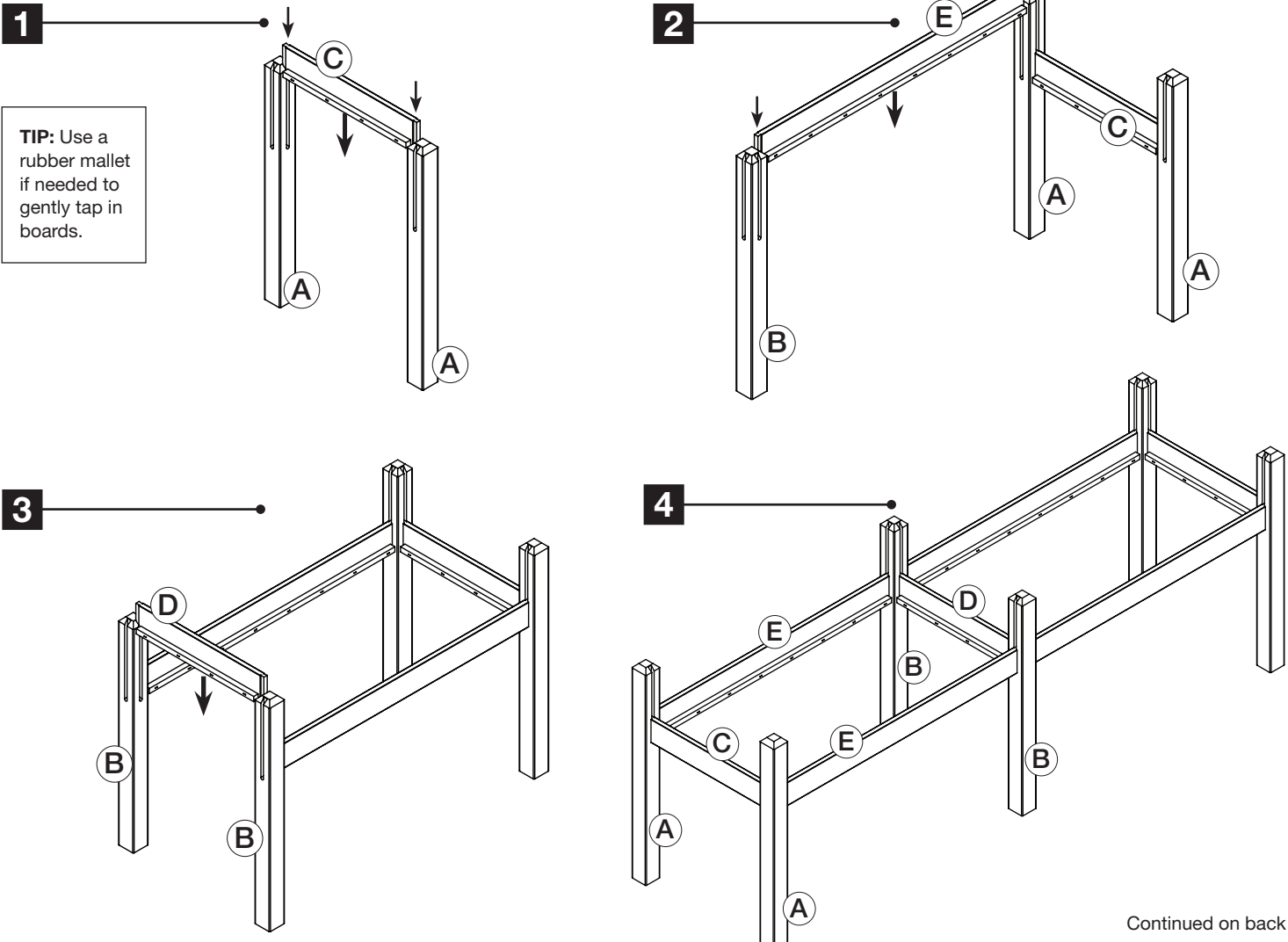

# HOMESTEAD 2X8 CEDAR ELEVATED GARDEN PLANTER

## ASSEMBLY INSTRUCTIONS continued

**Assembly – Step 2** Slide dovetailed boards into legs as shown.

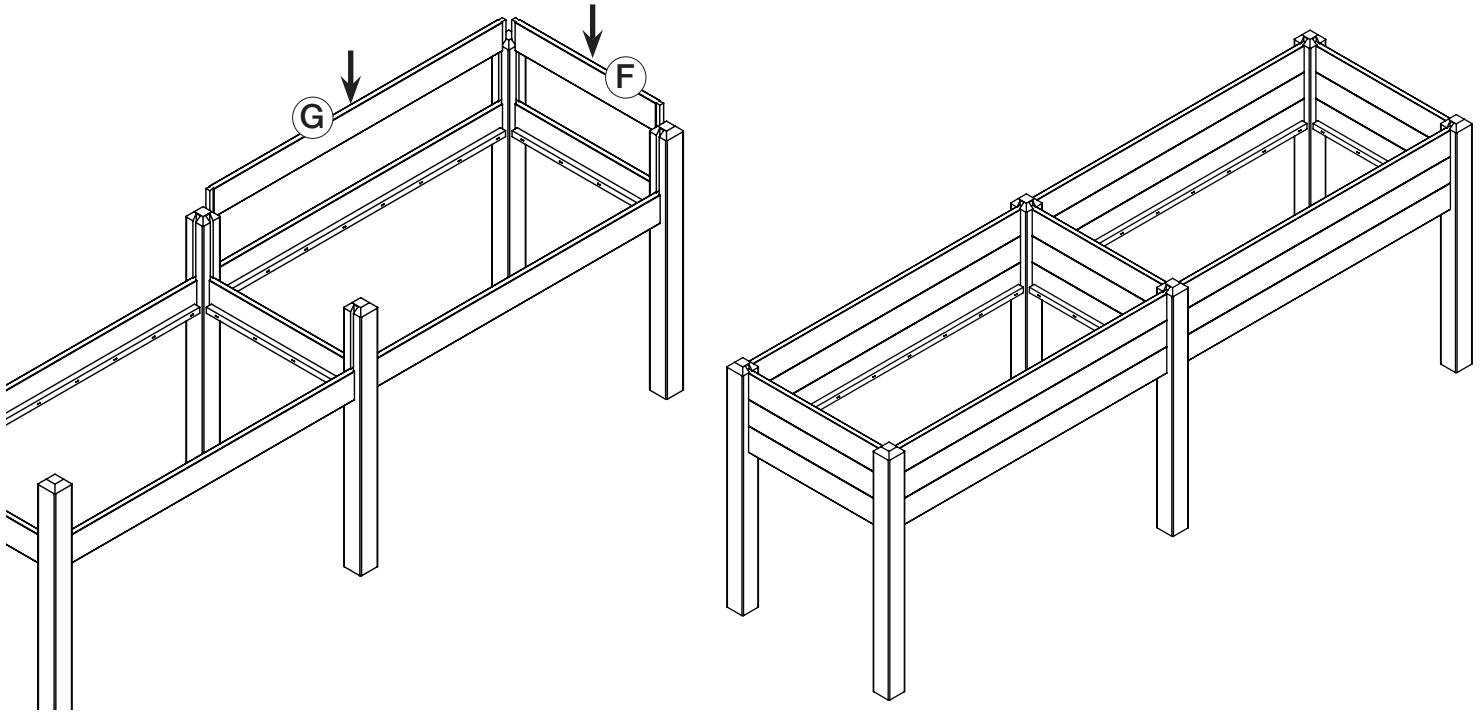

**Assembly – Step 3** Place bottom boards onto cleats to complete the planter.

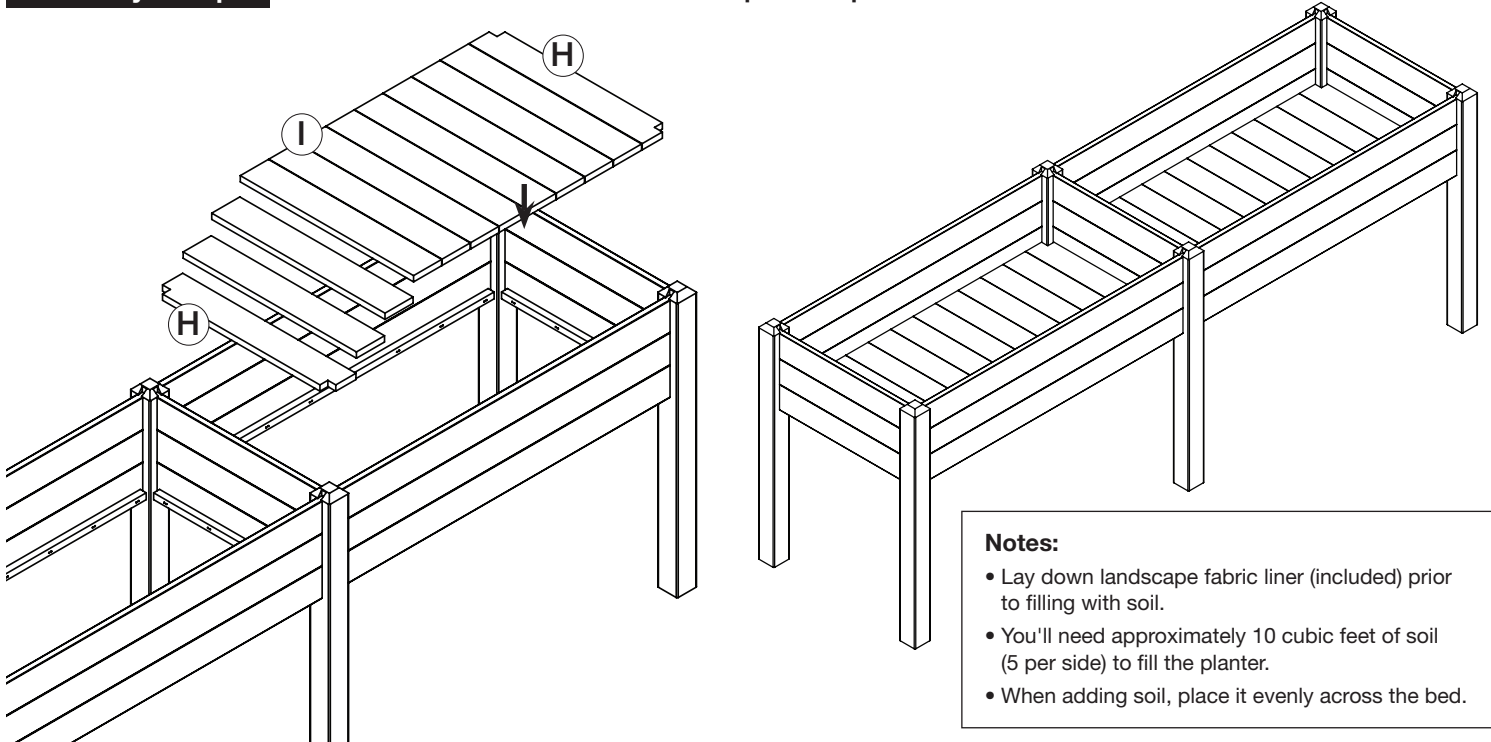

**Notes:**

- Lay down landscape fabric liner (included) prior to filling with soil.
- You'll need approximately 10 cubic feet of soil (5 per side) to fill the planter.
- When adding soil, place it evenly across the bed.

THE DIAGRAMS AND INSTRUCTIONS IN THIS BROCHURE ARE FOR ILLUSTRATION PURPOSES ONLY AND ARE NOT MEANT TO REPLACE A LICENSED PROFESSIONAL. ANY CONSTRUCTION OR USE OF THE PRODUCT MUST BE IN ACCORDANCE WITH ALL LOCAL ZONING AND/OR BUILDING CODES. THE CONSUMER ASSUMES ALL RISKS AND LIABILITY ASSOCIATED WITH THE CONSTRUCTION OR USE OF THIS PRODUCT. THE CONSUMER OR CONTRACTOR SHOULD TAKE ALL NECESSARY STEPS TO ENSURE THE SAFETY OF EVERYONE INVOLVED IN THE PROJECT, INCLUDING, BUT NOT LIMITED TO, WEARING THE APPROPRIATE SAFETY EQUIPMENT. EXCEPT AS CONTAINED IN THE WRITTEN LIMITED WARRANTY, THE WARRANTOR DOES NOT PROVIDE ANY OTHER WARRANTY, EITHER EXPRESS OR IMPLIED, AND SHALL NOT BE LIABLE FOR ANY DAMAGES, INCLUDING CONSEQUENTIAL DAMAGES.

©2022 Universal Forest Products, Inc. Outdoor Essentials is a registered trademark of Universal Forest Products.  
All rights reserved. 2801 East Beltline NE, Grand Rapids, MI 49525 14001\_1/22

[OutdoorEssentialProducts.com](http://OutdoorEssentialProducts.com)